

(12) INTERNATIONAL APPLICATION PUBLISHED UNDER THE PATENT COOPERATION TREATY (PCT)

(19) World Intellectual Property Organization
International Bureau



(43) International Publication Date
22 September 2005 (22.09.2005)

PCT

(10) International Publication Number
WO 2005/086574 A2

- (51) International Patent Classification: Not classified
- (21) International Application Number: PCT/IL2005/000137
- (22) International Filing Date: 4 February 2005 (04.02.2005)
- (25) Filing Language: English
- (26) Publication Language: English
- (30) Priority Data:

60/542,022	5 February 2004 (05.02.2004)	US
60/633,429	7 December 2004 (07.12.2004)	US
- (71) Applicant (for all designated States except US): REABIL-
ITY INC.; NERINE CHAMBERS, P.O. Box 905, Road
Town, Tortola (VG).
- (72) Inventors; and
- (75) Inventors/Applicants (for US only): EINAV, Omer
[IL/IL]; 42875 KFAR MONASH (IL). EINAV, Haim
[IL/IL]; 28 Shlush Street, 65149 Tel-Aviv (IL).
- (74) Agents: FENSTER, Paul et al.; FENSTER & COM-
PANY, INTELLECTUAL PROPERTY LTD., P.O. Box
10256, 49002 Petach Tikva (IL).
- (81) Designated States (unless otherwise indicated, for every
kind of national protection available): AE, AG, AL, AM,
AT, AU, AZ, BA, BB, BG, BR, BW, BY, BZ, CA, CH, CN,
CO, CR, CU, CZ, DE, DK, DM, DZ, EC, EE, EG, ES, FI,
GB, GD, GE, GH, GM, HR, HU, ID, IL, IN, IS, JP, KE,
KG, KP, KR, KZ, LC, LK, LR, LS, LT, LU, LV, MA, MD,
MG, MK, MN, MW, MX, MZ, NA, NI, NO, NZ, OM, PG,
PH, PL, PT, RO, RU, SC, SD, SE, SG, SK, SL, SM, SY, TJ,
TM, TN, TR, TT, TZ, UA, UG, US, UZ, VC, VN, YU, ZA,
ZM, ZW.
- (84) Designated States (unless otherwise indicated, for every
kind of regional protection available): ARIPO (BW, GH,
GM, KE, LS, MW, MZ, NA, SD, SL, SZ, TZ, UG, ZM,
ZW), Eurasian (AM, AZ, BY, KG, KZ, MD, RU, TJ, TM),
European (AT, BE, BG, CH, CY, CZ, DE, DK, EE, ES, FI,
FR, GB, GR, HU, IE, IS, IT, LT, LU, MC, NL, PL, PT, RO,
SE, SI, SK, TR), OAPI (BF, BJ, CF, CG, CI, CM, GA, GN,
GQ, GW, ML, MR, NE, SN, TD, TG).

Published:
— without international search report and to be republished
upon receipt of that report

For two-letter codes and other abbreviations, refer to the "Guid-
ance Notes on Codes and Abbreviations" appearing at the begin-
ning of each regular issue of the PCT Gazette.

WO 2005/086574 A2

(54) Title: REHABILITATION WITH MUSIC

(57) Abstract: Rehabilitation apparatus, comprising: at least one motion support element adapted to support a motion of a part of a human; a generator of rhythmic audio; and a controller configured to correlate an audio output of said generator and said supported motion.

REHABILITATION WITH MUSIC**RELATED APPLICATIONS**

This application claims the benefit under 119e of U.S. Provisional Applications No. 60/542,022 filed on February 5, 2004 and 60/633,429 filed on December 7, 2004, the disclosures of which are incorporated herein by reference. This application is also related to U.S. Provisional Application 60/566,078 filed on April 29, 2004; 60/566,079 filed on April 29, 2004; 60/604,615 filed on August 25, 2004; 60/633,442 filed on December 7, 2004; and 60/633,428 filed on December 7, 2004. This application is also related to PCT applications, being filed on same date and by the same applicant as the present application, entitled "Gait Rehabilitation Methods and Apparatuses"; "Neuromuscular Stimulation"; "Fine Motor Control Rehabilitation"; "Methods and Apparatuses for Rehabilitation Exercise and Training"; and "Methods and Apparatus for Rehabilitation and Training"; "Methods and Apparatus for Rehabilitation and Training"; and "Methods and Apparatus for Rehabilitation and Training"; and having attorney docket numbers, 414/04391; 414/04400; 414/04401; 414/04388; 414/04213, 414/04404; 414/04405, respectively. The disclosures of all these applications are incorporated herein by reference.

FIELD OF THE INVENTION

The present invention relates to rehabilitation, training and/or exercise using music.

BACKGROUND OF THE INVENTION

Rehabilitation of an injured person and/or training in the use of specific muscles requires tedious repetition of muscle movements. Generally such training is guided by a physical therapist or personal trainer teaching the person what moves to make and making sure that the person performs the moves.

People tend to get bored and tired of performing the exercises, especially if the motion is complicated, strenuous or causes pain.

Generally listening to music is considered enjoyable. Music typically transfers a rhythm to the listener and gives the user an urge to move. It is common practice to combine motion and music, for example as in dancing. Additionally, exercise and music are known to be combined, for example as in aerobics.

Music has also been used as background for physical therapy and rehabilitation.

SUMMARY OF THE INVENTION

An aspect of some embodiments of the invention, relates to devices that combines rehabilitation with music. In an exemplary embodiment of the invention, the device tracks a patient's motion and gives feedback to the patient (and/or a trainer or other person) using changes in music, for example indicating mistakes or generating comment such as an indication of speed of motion or smoothness of motion. In an exemplary embodiment of the invention, the device generates music to guide the person in performing rehabilitation. In one example, the device translates complex trajectories into music and music parameters that can be readily perceived. In another example, music is used to assist in synchronizing multiple body parts. In another example, music is used to give advance warning or a reminder of a change in motion, for example, a raising tempo indicating an upcoming change in direction of motion. In an exemplary embodiment of the invention, music is used as a guiding language for assisting in communication between an operator and a patient. In one example, an operator's motions are recorded spatially and using music and feedback to the operator on the quality of performance of such motions by a patient are provided using music.

In an exemplary embodiment of the invention, music is used for patients with cognitive impairment of the verbal system, who may not be able to understand, follow and/or generate verbal instructions or comment.

In some embodiments of the invention, music is used for physiological purposes, for example to motivate or calm down a patient, for example automatically in response to physiological sensing thereof. Optionally, music is used to convey general instructions, rather than instructions relating to a particular movement. In one example, music is used to indicate (e.g., a chime) that a series of exercises is reaching a last set.

In some embodiments of the invention music is used as an integral part of rehabilitation to add interest to the rehabilitation and/or fill in for times when a patient is too tired to perform an activity or during short rest periods. Optionally, music is used to provide motivation to a patient, e.g., a feeling that the exercises are actually having an effect on the real world.

In an exemplary embodiment of the invention, the use of music is used to convey a sense of time and/or timing to a rehabilitating person.

In some embodiments of the invention, a patient is required to move in a specific path or a desired location. Optionally alternatively or additionally, the patient is required to move at a specific rate or follow a particular tempo and/or rhythm.

In some embodiments of the invention, various sensors, such as position sensors, accelerometers or cameras are used to track the motion of a patient (or other user).

In some embodiments of the invention, a part of the device is attached to the patient and moves with the patient. Optionally, the device guides motion by prohibiting or hindering certain motion, for example exerting force to cause the patient to move in a manner which follows a specific path and/or use the same tempo as the pre-selected music.

In an exemplary embodiment of the invention, a pre-selected music is played for the user responsive to the user motion. Optionally the music is played correctly if the user motion is performed correctly, for example correct timing and/or in the correct position. In some embodiments of the invention, the music is distorted, for example played offbeat or off tune, if the user motion is performed incorrectly. In some embodiments of the invention, additional sounds are added to signify errors in the motion, for example beeps or a verbal response.

In some embodiments of the invention, the device coordinates between motions of different parts of a patient's body, for example different channels indicating motions of different body parts.

In some embodiments of the invention, the device coordinates between motions of multiple users. In one example, the multiple users are multiple patients, for example, organized as a band, with each patient's rehabilitation activities sounding a different instrument. Differences in patient's abilities are optionally bridged by suitable devices, for example, one patient may be required to keep to a tempo within 10% and another be required to keep a motion to be circle-like, without restriction on speed or rhythm and with a precision of 50%. In both cases, if the requirements are met the devices will produce synchronized correct music. A potential advantage of such a setup is that a patient can feel that he is a productive part of a group. This may also provide motivation. In another example, the multiple users are a patient and an instructor. In another example, the multiple users are a patient and a layperson, such as a family member, which may assist in ensuring family support.

In an exemplary embodiment of the invention, games for rehabilitation are provided. In one example, the rehabilitation device is played as an instrument, for example, a patient plays drums by moving the device. Optionally, virtual reality techniques are used to provide feedback. In one example, a screen (or helmet) shows how the patient is hitting the drum. Optionally, the generated music is used as in karaoke where the patient needs to add his instrument to a pre-recorded band. Optionally, a pre-recorded band is provided via a connection to a communications network, such as the Internet.

In some embodiments of the invention, another visual feedback is used, for example showing a person doing the correct motions or giving encouragement using a visual device, for example a computer screen or a television.

There is thus provided in accordance with an exemplary embodiment of the invention, apparatus, comprising:

at least one sensor which generates an indication of a motion of a user;

a rhythmic audio generator; and

a controller configured to control said generator to modify an audio output thereof according to a program of rehabilitation of a human. Optionally, said controller modifies said audio according to said indication.

There is also provided in accordance with an exemplary embodiment of the invention, rehabilitation apparatus, comprising:

at least one motion support element adapted to support a motion of a part of a human;

a generator of rhythmic audio; and

a controller configured to correlate an audio output of said generator and said supported motion.

Optionally, said motion support element is adapted for attachment to a human.

Optionally, said motion support element is adapted for gripping by a human.

In an exemplary embodiment of the invention, said motion support element is adapted to assist a movement by a human. Optionally, said assisting comprises moving a portion of said human. Alternatively or additionally, said assisting comprises following a motion of said human while providing at least part of a motive force. Alternatively or additionally, said assisting comprises restricting a motion of said human.

In an exemplary embodiment of the invention, said motion support element is adapted to resist a movement by a human. Optionally, said resistance is not spatially uniform.

In an exemplary embodiment of the invention, said motion support element initiates said motion. Optionally, said motion support element moves said human. Alternatively or additionally, said motion support cues said human to start said motion.

In an exemplary embodiment of the invention, said controller generates said audio responsive to a correctness of said motion. Optionally, said controller modifies said audio during a motion according to a correctness of said motion. Alternatively or additionally, said correctness is judged against a stored plan. Alternatively or additionally, wherein said correctness is judged against one or more criteria. Alternatively or additionally, wherein said

controller distorts said audio according to a degree of error of said motion.

In an exemplary embodiment of the invention, said controller generates said audio to be timed to a desired movement by said human. Alternatively or additionally, said audio is generated before said movement. Alternatively or additionally, said audio is generated in time
5 with said movement. Alternatively or additionally, said audio is generated during said movement including an anticipation of changes in said movement according to a plan stored in said controller.

In an exemplary embodiment of the invention, said controller is configured to generate a score according to a synchronization between movements to specific spatial locations and
10 said audio. Alternatively or additionally, said controller is configured to mix a predetermined musical stream and audio generated according to said motion.

In an exemplary embodiment of the invention, said controller comprises a memory that links musical elements with motion elements. Optionally, said controller generates said audio from musical elements corresponding to different body parts. Alternatively or additionally, said
15 controller generates said audio from musical elements corresponding to different motions.

In an exemplary embodiment of the invention, said controller generates said audio according to a difference between a desired motion and an actual motion.

In an exemplary embodiment of the invention, the apparatus comprises a sensor which generates an indication of said motion. Optionally, said controller generates a music stream
20 according to said motion. Alternatively or additionally, said controller generates said stream as a set of instructions prior to detecting motion of said human. Alternatively or additionally, said controller generates series of musical notes and corresponding spatial motions.

In an exemplary embodiment of the invention, said controller has stored therein a plurality of trajectories of motion of said human.

25 In an exemplary embodiment of the invention, said controller has stored therein a rehabilitation program for said human.

In an exemplary embodiment of the invention, said audio comprises music.

In an exemplary embodiment of the invention, said audio generator is adapted to modify existing music.

30 In an exemplary embodiment of the invention, said controller is adapted to detect a physiological indicator of said human and generate music responsive thereto.

There is also provided in accordance with an exemplary embodiment of the invention, rehabilitation apparatus comprising:

an audio generator;
at least one sensor adapted to sense a movement of a human;
a controller having stored therein rehabilitation information of a human,
wherein said controller is adapted to correlate said audio and said movement responsive
5 to said rehabilitation information. Optionally, said apparatus is portable by an unassisted
human. Optionally, said apparatus is wearable. Alternatively, said apparatus comprises a stable
base and at least one moving extension.

There is also provided in accordance with an exemplary embodiment of the invention, a
method of rehabilitation, comprising:

10 coupling a patient to a rehabilitation system;
performing a rehabilitation activity by said patient; and
automatically generating music correlated with said rehabilitation activity. Optionally,
automatically generating comprises providing at least one cue to said patient. Alternatively or
additionally, automatically generating comprises providing at least one musical instruction to
15 said patient. Alternatively or additionally, automatically generating comprises providing
feedback on a physical action using music. Alternatively or additionally, automatically
generating comprises providing said music to other rehabilitated patients.

In an exemplary embodiment of the invention, the method comprises selecting music
for a cognitively impaired patient.

20 In an exemplary embodiment of the invention, automatically generating comprises
generating music according to a correctness of motion.

In an exemplary embodiment of the invention, automatically generating comprises
generating music timed according to a desired motion.

In an exemplary embodiment of the invention, automatically generating comprises
25 requiring said patient to reach spatial locations according to a musical feature of said music.

In an exemplary embodiment of the invention, automatically generating comprises
generating a musical channel to overlay an existing musical channel according to a motion of
said patient.

In an exemplary embodiment of the invention, automatically generating music
30 comprises generating music to synchronize motions of different points in a body of said patient.

In an exemplary embodiment of the invention, automatically generating music
comprises said patient bringing music to said system.

BRIEF DESCRIPTION OF FIGURES

Particular exemplary embodiments of the invention will be described with reference to the following description of embodiments in conjunction with the figures, wherein identical structures, elements or parts which appear in more than one figure are generally labeled with a same or similar number in all the figures in which they appear, wherein:

Fig. 1A is a schematic illustration of a rehabilitation system 100 usable for integrating music and rehabilitation, in accordance with an exemplary embodiment of the invention;

Fig. 1B is a block diagram of a portion of a controller of Fig. 1A, in accordance with an exemplary embodiment of the invention;

Fig. 2 is a schematic illustration of a configuration including cameras and/or sensors for tracking user motion according to an exemplary embodiment of the invention;

Fig. 3 is a schematic illustration of a supportive input device according to an exemplary embodiment of the invention;

Fig. 4 is a flow diagram of a method of rehabilitating a user in accordance to an exemplary embodiment of the invention; and

Fig. 5 is a flow diagram of an alternative method of rehabilitating a user in accordance to an exemplary embodiment of the invention.

DETAILED DESCRIPTION OF EMBODIMENTS

Exemplary Device design

Fig. 1A is a schematic illustration of a rehabilitation system 100 usable for integrating music and rehabilitation, in accordance with an exemplary embodiment of the invention.

In an exemplary embodiment of the invention, rehabilitation system 100 comprises a controller, such as a personal computer 170 and an input device 160 for tracking user motion and inputting it into computer 170.

In an exemplary embodiment of the invention, input device 160 is optionally a standard input device of a computer, for example a joystick (not shown), a mouse 140, a keyboard 130, a trackball (not shown), a drawing tablet (not shown), a touch screen 180, a pedal 150 or any other standard input device. Alternatively or additionally, input device 160 is optionally a specially designed device, for example an articulated robot arm or other input devices as described in U.S. Pat. App. No. 60/542,022 and U.S. Pat. App. No. 60/633,442, the disclosures of which are incorporated herein by reference. In some embodiments of the invention, input device 160 is grasped by the user. Alternatively, input device 160 is attached to the user or supports a limb of the user depending on the type of motion performed with the input device as

described below. Optionally, different input devices with different degrees of freedom are used depending on the muscles of the user that need to be trained and the level of control the user has of the muscles.

5 In some embodiments of the invention, multiple input devices 160 are provided, for example, for providing input from two or more limbs.

In an exemplary embodiment of the invention, computer 170 comprises an output device, for example display 120, which may be used for giving instructions and/or responses to the user.

10 In an exemplary embodiment of the invention, rehabilitation system 100 comprises speakers 190 used for playing music and/or other audio signals. Other audio sources may be used as well, for example a head set, for example a Bluetooth wireless head set.

15 Fig. 1B is a block diagram of a portion of controller 170, in accordance with an exemplary embodiment of the invention. This portion may be implemented, for example, using software, using hardware and/or using a combination thereof. In some embodiments, other organizational structures than the one shown in Fig. 1B are used, for example, an electronic circuit or a neural network.

A sensor analysis module 172 receives signals from sensors, for example position sensors and pressure sensors. Data from encoders of input device 160 may be converted, for example, into position information.

20 A motion analysis module 174 analyzes motion as reflected by the positions of body limbs, for example, determining smoothness of motion and/or spatial shape and/or speed of the motion.

A processor 176 then applies one of the methods described below, for example, for controlling an audio generator 177. Optionally, a database 178 of desired motions and/or music
25 is used for applying such methods.

Fig. 2 is a schematic illustration of a rehabilitation configuration 200, which can serve as an input device 160 for rehabilitation system 100, according to an exemplary embodiment of the invention. In an exemplary embodiment of the invention, a disabled user 290, for example with a physical handicap, is seated in a chair 210. Optionally, user 290 is supported by a body
30 rest 220 if user 290 needs support. In an exemplary embodiment of the invention, chair 210 is fixated with fixation bars 230 to a control device 240. Control device 240 is used by user 290 to train a damaged limb, for example a hand or a foot. In an exemplary embodiment of the invention, control device 240 is connected to computer 170 and transmits details of the motion

performed by user 290. In some embodiments of the invention, control device 240 is controlled by computer 170 and trains user 290 by guiding the limb of user 290 to perform a specific motion. In some embodiments of the invention, the user's limb is attached to control device 240, for example using a strap, to prevent control device 240 from slipping away from the grasp of user 290. Control device 240 can be of various types, for example, it can be a ball with motors and/or a brake and an optional extending handle. Encoders may be provided on the ball and/or the handle, or on motors thereof. In another embodiment, control device 240 is an articulated robotic arm. Force sensors may be provided in the robotic arm. Pressure sensors may also be attached to parts of the body in contact with parts of system 100 or in contact with other items.

In some embodiments of the invention, rehabilitation device 200 comprises cameras or sensors 270 to detect the motion of user 290. Optionally, user 290 wears markers 260, for example fiducial markers or transmitters to allow recording of the motion of a whole limb or other parts of the body of user 290. In some embodiments of the invention, the markers are passive markers that allow an external device to record motion based on them. Alternatively or additionally, the markers are active devices that sense and transmit a characteristic of the user motion, for example an accelerometer that transmits acceleration, speed or an inclination sensor that senses and transmits the inclination of the sensor on the user relative to the perpendicular. Optionally, the markers include a feedback element that can provide feedback to patient, for example nudging the patient to move a limb in sync with the music. In an exemplary embodiment of the invention, cameras or sensors 270 transmit details of the motion of user 290 to computer 170 in order to record the motion and prepare feedback based on the motion. In some embodiments of the invention, cameras or sensors 270 track an absolute position of user 290 as a function of time. Alternatively or additionally, cameras or sensors 270 record a user's speed or acceleration.

Depending on the type of sensor used, one or more of the following informational items about the motion may be determined: speed, position, smoothness, acceleration, applied force and/or characteristic frequencies, for example of tremor. These characteristics can be, for example of particular parts of a body (e.g., a hand) or of multiple body parts taking part in a same motion (e.g., hand, wrist elbow and shoulder).

In some embodiments of the invention, sensors 270 comprise one or more physiological sensors, which record physiological parameters of a user, for example pulse rate, EMG, EEG, muscle tension and/or breathing rate. In an exemplary embodiment of the invention,

rehabilitation system 100 responds immediately to these parameters, for example stop the exercise if the user is over stressed. Alternatively, the parameters may serve for general user progress reports. In an exemplary embodiment of the invention, the pulse rate is used as a feedback to vary music tempo, for example, to match to a speed, for providing feedback to the patient and/or to provide feedback to a caretaker. The actual signal may be indicative of limits rather than absolute values. In an exemplary embodiment of the invention, if stressing of the patient is determined, calming music is played, to reduce such tension. In other embodiments, for example, sensing EEG and EMG, the sensed signals relate directly to the rehabilitation, for example indicating correct (or incorrect) cognitive activation or muscle activation attempts. US provisional applications 60/604,615 and 60/566,078, the disclosures of which are incorporated herein by reference, describe examples of using EMG and EEG signals as part of rehabilitation.

While the present application focuses on audio presentation, in some embodiments of the invention, the audio presentation is supplemented by visual presentation. In one example, system 100 controls a DVD player or uses a TV set or a set-top box to display instructions and/or feedback. Optionally, visual rhythmic signals, for example, color waves are used instead of audio rhythmic signals, for example for deaf patients. The use of dual mode presentation may be helpful in some pathologies. It should be noted that control device 240 itself can serve as a feedback device, for example by vibrating or applying force, thus possibly providing three modes of feedback.

In an exemplary embodiment of the invention, musical feedback and/or instruction is used to assist in rehabilitating blind patients.

Fig. 3 is a schematic illustration of a supportive input device 300 according to an exemplary embodiment of the invention. In the embodiment of the invention shown in Fig. 3 a user's limb is strapped to plates 320 with straps 330. Optionally, the plates are mounted at the end of an articulated robot arm 310. In an exemplary embodiment of the invention, computer 170 is able to train a user's limb by controlling the movement of the user's limb with articulated robot arm 310 and/or moving plates 320.

Types of Motion

In some embodiments of the invention, rehabilitation system 100 is used in training users with different ability levels. As illustrated in Fig's 1-3 various devices can be used to affect different levels of control in training user 290 according to the ability of user 290. In some cases, user 290 has full control over the movement of the limb being trained. In other

cases, user 290 has limited control or is only able to feel movement. In yet other cases, user 290 is unable to control or feel the limb.

In an exemplary embodiment of the invention, the ability of user 290 is taken into account in defining the type of motion user 290 is required to perform. In some cases, user 290 is required to repeat a specific motion or perform a specific motion, for example a circle or straight line. When the motion is being generated (by the user or the system) a musical or auditory cue and feedback is optionally given. The user rhythm is optionally measured and can be corrected or the user can be asked to correct it. Optionally, rehabilitation system 100 is programmed to be passive and allow any user motion. Alternatively or additionally, rehabilitation system 100 may offer resistance at various levels to the user's motion. In some embodiments of the invention the resistance may be uniform over a trajectory performed by the user. Alternatively or additionally, the resistance may act like a force field offering varying resistance at different points of the force field. In other cases rehabilitation system 100 is programmed to assist the user in moving his or her limb along a selected trajectory, for example once an initial motion in a correct direction was applied. In some cases system 100 corrects user mistakes, for example to within a predefined tolerance (e.g., if motion is in a generally correct direction, it is constrained to the exactly correct direction). In some cases rehabilitation system 100 may force the user to perform a specific motion. In one example, both the tempo of the music and the force applied by system 100 are directed towards causing a user to perform a motion at a desired velocity profile. In other cases, system 100 may apply force only if a user strays from a trajectory more than a given amount. In other cases, system 100 may remind the user of a required motion by providing a nudge. In some cases, system 100 serves to smooth user motion. Optionally, the intended motion is detected by measuring force applied by the user against control device 240.

In an exemplary embodiment of the invention, if input device 160 is assisting, resisting or forcing a user to perform motion rehabilitation system 100 measures the level of resistance of the user to the required motion, for example the measure of force the user exerts in different directions.

In an exemplary embodiment of the invention, the degree of resistance/assistance may be changed, for example, to determine a user's ability. Optionally, music used as a tempo or rhythm for rehabilitation is changed, for such testing.

Optionally, the quality of motion and/or a patient's ability are measured on a musical scale, for example, of accuracy, clarity, and/or pleasantness.

Instruction

In an exemplary embodiment of the invention, a user is instructed visually, for example by the required motion being displayed on a display device, for example display 120 or a TV screen. Alternatively or additionally, the required motion is requested verbally, for example
5 "move left hand up and down". In some embodiments of the invention the user can perform any type of motion as long as it correlates to attributes dictated by the music, for example tempo or path interval. Optionally the chosen user motion may be limited by input device 160, for example the user may move in any direction as long as he or she is grasping input device 160, which may apply a constraint on motion, for example a position and/or velocity constraint.

10 In an exemplary embodiment of the invention, the user motion is displayed to the user as movement in a virtual world, for example a user's limb is shown as a controllable object on a display (e.g., goggles or a helmet) showing the virtual world. Optionally the virtual world may provide tasks which need to be performed by the user, for example touching certain objects or pushing objects with a minimum force.

15 A particular feature of some embodiments of the invention is the ability to bypass damaged neuronal pathways. In an exemplary embodiment of the invention, a user is instructed using music, rather than, or in addition to verbally and/or visually. In an exemplary embodiment of the invention, a stroke victim is taught a relationship between music and motion, for example by allowing motion and playing different music to match each motion. A
20 more structured approach may be used as well, for example, moving a limb and playing suitable music at the same time. In an exemplary embodiment of the invention, system 100 coordinates the movement with the music, for example playing a predetermined music for each motion detected by it. Optionally, the effect of speed, smoothness, tremor and voice are also taught as affecting musical playback, for example, affecting one or more of tempo, one or more
5 channels, amplitude, type of instrument and/or special effects (e.g., echo).

Once taught the rudiments of a musical language, physical rehabilitation can proceed in parallel with any speech rehabilitation.

In an exemplary embodiment of the invention, system 100 is designed to operate under voice control. In one example, the system is trained to recognize simple commands, like
0 "stop", "slow down", "next" and "repeat". Optionally, the system recognizes musical commands, for example, whistling or rhythmic motion of control device 240. Alternatively or additionally, spatial gestures using device 240 are recognized. Optionally, musical feedback is

provided to assist a user in determining that he made a correct gesture, while the gesture is being made and without necessarily requiring looking at the moving limb.

In an exemplary embodiment of the invention, instruction is provided by control device 240 moving, possibly while the user holds on to it. As will be described below, such a demonstration may also be accompanied by a musical playback.

Using Music for Feedback

Fig. 4 is a flow diagram 400 of a method of rehabilitating a user using system 100, according to an exemplary embodiment of the invention. In an exemplary embodiment of the invention, a user is positioned (410) relative to rehabilitation system 100. In some cases, this may require strapping in. In some embodiments of the invention, the user optionally logs on (420) to computer 170 of rehabilitation system 100, so that system 100 can keep track of a user's progress, for example if the user is performing the required motion more accurately as a result of continuous practice. Alternatively rehabilitation system 100 is intended for a single user or a user supplies his or her personal data, for example on a diskette or other types of removable media. Optionally a user logs in using a smart card. Data regarding the user may be stored at a remote location. Optionally, the rehabilitation session is managed over a network, such as the Internet 185, for example a local network or a wide area network.

At 430, the user selects a rehabilitation program that is required for the user, for example the user may select between different stress levels or programs for dealing with different limbs. Optionally, the user selects between programs that perform different motion trajectories, for example moving in a curved path (e.g., a circle, an ellipse) or moving in a straight path (e.g., a line, a rectangle or forward and backward). As can be appreciated, in some cases, some of the above tasks of positioning, logging in and selecting an exercise may be performed by an operator, rather than by a patient. The selection of available exercises may be set in many ways, for example, automatically, according to a progress plan of the patient or manually, by an operator. Various rehabilitation parameters may be set, for example, limits, accuracy required, repetitions and/or any parameter known in the art.

In some embodiments of the invention, the rehabilitation program may be represented by a specific music, which the user is required to create by performing a motion matching the tempo of the selected music, for example moving at a specific rate and/or following a specific path. In some embodiments of the invention, the required motion is displayed to the user on display 120 (or control device 240 demonstrates it by moving itself) and the user is required to

imitate the displayed motion. Music is optionally played during the demonstration and the same music is optionally generated if (and as) the user repeats the demonstrated motion.

At 432, one or more music parameters are optionally selected, for example, including one or more of music type (for example, quiet music or loud music), linkage of musical parameters to rehabilitation parameters (e.g., physiological or motion parameters).

In an exemplary embodiment of the invention, the music or class of music defines the stress level by defining a faster or slower tempo and/or a larger or smaller interval of motion, which is optionally related to attributes of the music.

In addition, music for setting an atmosphere may be selected.

Optionally, rehabilitation system 100 plays (440) the selected music. Optionally, the user brings music to be played on known media. The user is required to perform (450) a motion which is tracked by rehabilitation system 100 according to methods mentioned above. Optionally, the required motion and the music are selected and/or modified to match (and optionally provide guidance), for example as will be described below. In other embodiments, music is played only in response to a user motion, rather than during motion and/or being modified by the motion. In some cases, the user is not required to carry out a particular motion, rather any motion he carries out may have constraints set thereon, or free motion may be allowed.

In an exemplary embodiment of the invention, the music is synchronized to motion of control device 240, in that correct motion will create correct music. In another example, the motion of device 240 is made to match that of the music. In another example, device 240 assists, nudges and/or corrects a user motion so that it will match the music.

In an exemplary embodiment of the invention, rehabilitation system 100 measures and optionally records (460) the user motion as described above, for example by physical contact with an input to rehabilitation system 100 (e.g., a user grasping input device 160) or by non-physical contact with an input to rehabilitation system 100 (e.g., a camera recording the motion from a distance).

In an exemplary embodiment of the invention, rehabilitation system 100 analyzes (470) the recorded motion relative to the required motion to determine a level of correlation. In some embodiments of the invention, the analyzed results are logged for each user to determine their relative ability and/or if the user shows improvement.

In an exemplary embodiment of the invention, rehabilitation system 100 issues (480) a response to the user motion. In some embodiments of the invention, deviation from the

required path is followed by an immediate response, for example distortion of the music being played and/or additional audio sounds such as beeps or other noises. Alternatively or additionally, rehabilitation system 100 may respond with a report after finishing an exercise session regarding the user's ability. In some embodiments of the invention, rehabilitation system 100 issues a report based on details from multiple uses of the device by a user. The report optionally deals with the improvement or lack of improvement of a user.

Immediate responses can be, for example discrete or continuous. In an example of a discrete response, a tone is played when a motion segment is correct or incorrect. In an example of a continuous response, a tempo relates to the speed of motion, like a metronome keeping the "beat" of the motion. In another example of a continuous response, the motion is construed to reflect a portion of music and system 100 plays a matching counter point. Possibly, two sets of feedback are thus available, one set in the music corresponding to the motion and one in the counterpoint music.

In an exemplary embodiment of the invention, a wave (or other format) file is pre-selected for each motion and/or for each position in space. If the position/motion is not reached exactly and/or on time, a distorted file will be played. Optionally, the distorted file includes a hint for one or more of amplitude of the error and direction of error.

It should be noted that not all parameters of the motion need to be responded to using music. For example, only one or more of the possible parameters are related to music. In one example, tempo is used for feedback on the speed of the motion, but the position is analyzed and presented using visual or kinesthetic means.

In an exemplary embodiment of the invention, the method of Fig. 4 is used for special rehabilitation exercises, for example arm rotations. Alternatively or additionally, this method is used for rehabilitation of daily activities. For example, different pieces of music may be associated with different activities, such as brushing teeth, tying shoelaces or walking. The music may serve as a reminder to the patient after rehabilitation is completed.

Using music to guide

Fig. 5 is a flow diagram 500 of an alternative method of rehabilitating a user with rehabilitation system 100 in accordance with an exemplary embodiment of the invention. As in Fig. 4, a user is positioned (510) relative to rehabilitation system 100 and optionally logs on (520). After logging on, the user optionally selects (530) a specific rehabilitation program to perform.

At 532, musical parameters are selected to match the program. In an exemplary embodiment of the invention, the parameters are selected in a way which will guide a user, for example as described below. Selection may be, for example, automatic, from a table or manually.

5 At 534, the music is played and serves as a guide for a user performing a motion (540). In an exemplary embodiment of the invention, the music serves as a guide in one or more of the following manners:

(a) Tempo is used to tell user, for example, how fast to move, relative motion speeds (self calibration) and/or when to move. In particular, background music/tempo can be used to
10 set the pace for the whole exercise or change during exercise as the user gets warmed up and/or slow down when the end is approaching. The user being warmed up may be detected, for example using physiological parameters, or based on time considerations. Also background music can be used to add interest during rest periods and/or during an exercise. Optionally, the music slows down when the patient stops and speeds up when motivation to try again is to be
15 applied (e.g., decided manually or automatically).

(b) Feedback in general, for example as described with respect to Fig. 4, in that music is distorted by incorrect movement.

(c) Guidance on expected length of exercise and on time to do repetitions (for repetitive music).

20 (d) Training, in which music is used to train in doing exercises. For example, different musical phrases can be different motions which a patient learns. In another example, a set of morning exercises (tai chi) are taught using matching music.

(e) Synchronizing different body parts, for example, by a particular phase indicating combined motion or by first teaching each separate motion with its own music and then
25 combining the motions and the music.

(f) Anticipation, for example by generating a tone or changing amplitude before a change of motion is required.

(g) Instruction, for example, particular musical phrases meaning "go to starting point", "faster" or "time to slow down".

30 (h) Warning. Music can be used to warn a user that he is approaching a point where he earlier felt pain or a point where a joint is unstable and care should be taken.

(i) Sequence of tones, with or without a given tempo, can be related to sequence of motion (e.g. to teach correct throwing of a ball, kicking, dancing).

In some embodiments of the invention, the user's motion is measured (550) by rehabilitation system 100. Optionally, rehabilitation system 100 analyzes (560) the motion to match it to music and/or sounds based on the user's motion, for example the position of the user's limb, the rate of motion and/or acceleration. Exemplary feedback methods were described above. Optionally, in method 500, music and/or additional sounds are created (570) and optionally played for the user on the fly according to the user motion, for example music of a selected song is recreated with a tempo based on the rate of the user's motion. In another example, the movements emulate playing on a musical instrument.

In an exemplary embodiment of the invention, guidance and/or feedback are used to give a patient a sense of time and/or a sense of timing.

Record and playback

In an exemplary embodiment of the invention, motions are programmed into system 100 by an instructor, in combination with music. For example, an instructor can show a correct motion and match it to music after the fact or perform to music. In an exemplary embodiment of the invention, position sensors (e.g., as shown in Fig. 2) are attached to the instructor and the position of various body parts recorded. In another example, the instructor moves the patient's limbs in a demonstration which is recorded, for later repetition by the patient. In an exemplary embodiment of the invention, the position sensors include electrical or vibrational stimulators.

In one example, the location change of each position sensor is recorded to a music-look up table of the following (or similar) form:

Tune (name)	File name	Tempo		
Yesterday	Yest.wav	xxx		
Joint identifiers	Joint 1	Joint 2	Joint 3	Joint x
	Left elbow	Right elbow	Left knee	Right knee
Musical Bar #	Joint 1	Joint 2	Joint 3	Joint x
1	No motion	+	-	+
2	+	No	-	-
3	+	no	+	-

Where "+" indicates motion away from the body.

During playback, the patient plays the music (e.g., thru earphones). Controller 170 signals to each stimulator based on the above table and the patient responds accordingly. Position sensing and/or accelerometers may be used to determine if the motion is correct and optionally provide musical feedback

Integrated motion controller

In an exemplary embodiment of the invention, a musical rehabilitation/exercise device is made portable. Such a device includes a controller and a plurality of stimulation patches. Headphones, optionally wireless are used to play music. The controller stimulates the patches according to the desired response by the user. Optionally, patches are provided in pairs or in
5 greater numbers, for example for providing stimulation to a joint from multiple directions. Optionally, the patches include position sensors and/or accelerometers (or such are separately provided) for reporting to the controller the patient's response. In an exemplary embodiment of the invention, such a device is used for assistance in daily activities, with the stimulation and the music serving as reminders for the motions to be carried out. The stimulators and/or sensors
10 may be provided in an article of clothing, for example a vest and/or be wireless. Optionally, the stimulation is electrical or vibrational. For deaf patients, vibration can be used to convey the rhythm and/or content of music, instead of audio.

Body synchronization

As noted above, in an exemplary embodiment of the invention, musical means are used
15 to help a patient synchronize motions between different body parts. In one example, a rehabilitation process is broken down into separate processes for each body part or for different motions of a same body part. Then a complex motion is guided by playing the music of multiple motions serially or in parallel, as appropriate. Delay in one channel may be used to indicate that its corresponding motion should be speeded up. In an exemplary embodiment of
20 the invention, different body parts and/or motion are provided with different instrumental sounds.

In an alternative embodiment of the invention, music is used to indicate specifically the synchronization. For example, a piece of music is played correctly only if synchronization is correct, possibly using the same instruments for each body part as using during training. As
25 noted above, the use of certain musical themes may be standardized so as to create a musical language. In one example, the left leg is always the sound of a flute and the right leg always an organ.

In an exemplary embodiment of the invention, rehabilitation system 100 and/or input device 160 may record motion from two limbs (e.g. arms or legs) simultaneously. In an
30 exemplary embodiment of the invention, the user is required to perform an identical motion with both limbs. Alternatively or additionally, the user is required to perform mirrored motion, where the two limbs are required to perform mirrored motion. Optionally, the user is required

to perform complementary motion or motion with a correlation between different limbs, for example throw an object from one hand to another.

Instrument playing

In an exemplary embodiment of the invention, music is generated as if a user had one or more instruments. This may be part of a free-play session or it may be part of an exercise where particular motions are mandated. In an exemplary embodiment of the invention, the created music are selected according to the type of motion, for example a user can imitate playing a specific instrument such as a drum, guitar, violin, flute or any other instrument with a distinct playing pattern. In an exemplary embodiment of the invention, the various instruments are "positioned" in space, either as real instruments or as locations where they can be played by suitable motions. In an exemplary embodiment of the invention, a user plays such instruments in sequence, for example as set up by a therapist. Optionally, background music is provided to which such playing is to be synchronized. Optionally, the instruments are visible using virtual reality methods. Alternatively or additionally, the instruments include a light or other visual indication to remind a user when to "play" them. Optionally, an audible indication is used. Optionally, this allows different spatial locations to be mapped to musical sounds and/or instruments, as part of a rehabilitation language. In a session with pre-set motions, the musical generation may be made relative to the motions (e.g., to one or more of spatial, acceleration, force and/or velocity parameters). Alternatively or additionally, the generation is fixed in space. Optionally, as a user improves, the complexity of music created is increased. Alternatively or additionally, the degree of assistance is reduced. For example, a starting user may have a whole phrase generated just for making a motion, as time progresses, the user may get to a point where only a single note is generated and only if a correct motion is made. Exemplary intermediate levels are playing of a set of instruments, playing of a cord and triggering playback of channels.

In some embodiments of the invention, other parameters of the created music are selected by other aspects of the user motion, for example the height at which the motion is performed.

In an exemplary embodiment of the invention, control device 240 is used as a musical instrument. In one example, different locations, motions, speeds, and/or other musical parameters can make musical sounds. In an exemplary embodiment of the invention, the plane is mapped to various tones and the Z position is mapped to octave. Similarly, a mapping may be made in spherical coordinates. Optionally, the mapping matches a physiological motion. For

example, the plane to which tones are matched is the surface of the edge of motion of a hand, with the octave being set based on the degree of bending of the elbow. This can give a user a feeling for range of motion and change in range of motion, especially if there is a problem with self-kinesthetic feedback.

5 In a tempo-teaching example, a user can reach for an instrument and a tone is generated only if the movement matched the tempo. Optionally, a time constraint is applied. Optionally, rehabilitation using music can be used to single out individual issues to be rehabilitated. For example, a user can perform an exercise whose purpose is to make a movement (e.g., any movement, a semi-correct movement, an exactly correct movement) at a given time.
10 Conversely, rehabilitation can focus on the motion and provide music relating to the correctness of motion (e.g., music is fine as long as motion is within bounds) without training timing at the same time.

 In a more complex example, a drum machine may be emulated, where different drums and other percussion instruments are positioned in different target volume of space. The
15 applied force is easy to portray using amplitude.

 Two drum sticks or a stick and a pedal (e.g., with position sensors) may be used for training two body parts simultaneously. System 100 can be used to demonstrate or instruct the user online on how to perform the music correctly. In general it should be noted that system 100 can stop a session and restart it or provide additional instruction or motivation, if results
20 achieved by a user indicate it would be useful.

Multi-user applications

 In some embodiments of the invention, rehabilitation system 100 coordinates between multiple users, for example allowing competition between them or cooperative game playing. Optionally, the motion of different users can be assisted or hindered in order to reach a
25 common level of complexity for users with varying ability. In some embodiments of the invention, a single rehabilitation system 100 can track multiple limbs and/or users, for example using a single camera and/or a single computer 170. Alternatively or additionally, multiple input devices 160 are used. In some embodiments of the invention, multiple computers 170 are used. Optionally, multiple users can practice or compete together over a communication line,
30 for example multiple users each with a rehabilitation system 100 can participate in a common virtual reality environment over a LAN or the Internet 185.

 A particular example of cooperation is in music making. Each user can have a different instrument. Optionally system 100 provides support (for example correction of movements) so

that even severely impaired patients can take part. A potential advantage of such a setup is that impaired people can feel useful and take part in social activities, where a realistic level of participation is expected of them. Such a level is optionally determined by a therapist or automatically based on performance in exercises.

5 In an exemplary embodiment of the invention, music is used in a group therapy so that it is easy to portray to other users what a user did wrong. This is especially true if there are physical problems, such as the users being distributed and having a limited bandwidth and/or no cameras. Alternatively or additionally, music is used to help explain what motions were done.

10 In another example, a therapist or a computer acts as a conductor to guide a group session. In one example, a control device 240 is moved and music is sounded and the users repeat. This can be done in a band setting or not. As the users show their ability, the process may be made more complex and/or speeded up. As noted above, by providing support to weak users, such weak users can partake also if complexity increases by system 100 hiding such
15 complexity and/or increasing a correction function of system 100.

 In some cases, the users compete with each other, for example, to see who can create clearest music or while playing a game. Optionally, system 100 is used to even the odds between users of different abilities.

Healthy-and-patient example

20 A particular example where music can be used to synchronize between multiple users is a therapist and a patient, where the music is used to synchronize their motions and/or allow the therapist to focus on a smaller number of mistakes in the motion, with other mistakes being "pointed out" by the music.

 Another example is a home setting, where, for example, a layperson assists an elderly
25 parent in rehabilitation. System 100 can compensate for lack of knowledge by providing music which guides both the healthy person and the parent-patient. The music serves to indicate what is correct and what should be corrected and the layperson can focus on caring and on helping such corrections to be carried out. It is believed that system 100 can thus reduce frustration and increase closeness in families with crippled members.

Musical variations

30 As used herein, music is any type of audio with rhythm and can include, for example, chanting, and reading of prose, as well as periodic beeping. It is believed, however, the complex music and interesting music can have special benefit in providing multiple feedback

possibilities, detailed feedback and/or interest. In particular, music can range between children's rhymes and complex orchestral pieces, for example, rock music, folksongs and pieces composed for a small number of instruments (e.g., 1, 2, 4 or 8).

5 In an exemplary embodiment of the invention, music is selected according to user preference. For example, a plurality of groups of music are available and a user selects one group. For example, groups can be "Rock", "Pop", Baroque" and "Chanting". Each group includes elements which can be used for the various uses described herein.

10 In an exemplary embodiment of the invention, music is selected for a particular rehabilitation task based on one or more of pace, beat, number of channels, regularity, existence, number and/or location of clearly identifiable turning points and liking and/or familiarity of the patient.

15 As noted above, different users have different abilities, so the actual parameters controlled by the user in a particular session may vary. For example, the parameters used may depend on one or more of: complexity of exercise, proficiency of user in music, rehabilitation stage of the user, ability of therapist, presence of participating group and/or mood.

20 In an exemplary embodiment of the invention, it is appreciated that a user is in a learning process when using music. Thus the complexity and/or speed of the music may increase over time. In an exemplary embodiment of the invention, the complexity, duration, type and/or difficulty of rehabilitation exercises increase over time, possibly at a different rate than music. In an exemplary embodiment of the invention, the number of instruments, tunes chords and/or cords used during rehabilitation is gradually increased. Optionally, additional musical variation (e.g., additional channels or instruments in an already existing musical piece) is introduced when a user shows advancing rehabilitation proficiency in one example, a vocal channel is added to provide feedback on smoothness of motion, once a user has shown
25 proficiency in an exercise in which an instrument channel is linked to accuracy in controlling direction of motion.

30 In an exemplary embodiment of the invention, fixed parameters of music are mapped to rehabilitation parameters, for example, smoothness is linked to random variation in amplitude and accuracy of motion is linked to accuracy in reproduction of amplitude, frequency and/or tempo. As noted, different exercise may have different mappings. For example, in one exercise, any error smaller than 3 cm in position is ignored. In another, the effect of error on distortion of music is linear. In another, the effect is non-linear, for example exponential. The effect may be directional (e.g., increase in one direction and decrease in the other) or uni-directional, for

example decrease in any direction away from correct direction. The term directions is used to represent any motion parameter, including one or more of position, velocity acceleration and force. Different effects may be used for patients with different disorders and/or depending on their stage or type of rehabilitation exercise used.

5 In some cases, music is used for psychological effect, in which case the effect of particular music on the patient is optionally gauged in a calibration session or over time. In one example, music is used to calm a patient who is over exerting. In some cases the effect is direct on the patient's emotions, in others the music serves as a signal to the patient (or therapist), or as a mirror of his emotional response.

10 In an exemplary embodiment of the invention, a user can provide his own music, for example a favorite music provided on CD. Such music can be used as background music or for a Karaoke game. In an exemplary embodiment of the invention, the music is analyzed (e.g., divided into channels) for use in rehabilitation. Optionally, the variations in the music which signify feedback and/or guidance are illustrated to the user prior to or during rehabilitation.

15 Games

In an exemplary embodiment of the invention, music is used to provide fun during rehabilitation. In some embodiments, system 100 is used to support games, for example, single player games or multi-player games.

20 One example of a game is "Hit on Beat" in which a player gains points (or plays a sound) by reaching a desired spatial location and/or speed and/or acceleration and/or force at a time that coincides with a beat of music and/or before a musical timer runs out. Repeated "hits" may be supported.

Another example is "Musical Simon". Control device 240 makes a motion while patient 290 holds on and also sounds music at a same time. In a later level, possibly only the sound
25 will be provided and the user will need to reconstruct the motion from memory. Only repeating correct motion (e.g., particular parameters such as position, velocity or others) and a correct sequence, will provide points. The motion may be constrained and/or assisted as described above. In a variant, the game is discrete and particular locations in space are associated with music. Repeating a set of musical tones requires a correct spatial motion sequence. Graphics
30 are optionally used for visualization. In one example, a patient uses VR (or TV screen with graphical representation of motion), with different musical instruments each corresponding to a spatial target. The target size, shape and position can depend on the desired rehabilitation.

In a particular example, system 100 is used as a cursor input device, with cursor positions mapped according to a particular rehabilitation exercise (e.g., drawing a circle, flexing an arm, etc.). The rules can be as follows: The game displays four different graphical signs. The player needs to replay the tracks by the moving the cursor to the graphical signs in the same order. For each iteration, the series of tracks grows one track longer, making it harder to replay the tracks in the correct order. For each good repeat the player will be awarded 1000 points. For out-of-tempo repeat he will be awarded 500 points. After the first wrong repeat the game will end and display a Game Over message and the score. The goal is to win as many points as possible. This is done by remembering as many musical notes as possible. The difficulty level can determine the music tempo.

In an exemplary embodiment of the invention, an interface module (software and/or hardware) is provided so that many cursor or joystick controlled games can be controlled using input device 160. The game may be on a same or on a different computer.

In general (for games and otherwise), exercises can be made more difficult by elongating the chain of causality between the instruction to the user and his performance. A shortest chain is the patient repeating a motion shown by a control 240. Intermediate is trying to reproduce a sound sequence (though sounds can be used as a hint to assist in a short-chain example). A still longer chain is a patient being taught spatial locations corresponding to sounds or instruments and expecting the patient to chain them together (e.g., plan motion trajectories) in response to hearing and anticipating a piece of music. This can train the speed and other characteristics of motion trajectory planning. In one example, some musical channels are provided and the patient provides the others. In another example, only words are shown and the patient needs to provide the music or only parts of it, for example a rhythm (absolute or relative values). As can be appreciated, music and motion control can be used to assist in cognitive rehabilitation, for example, for shape discrimination (e.g., recognizing shapes based on hand being moved along their outline and being shown), verbal processing (matching words to rhythm and/or motion), planning (e.g., of motion) and symbol sequencing (by doing ordered motion).

Another example of a game is Karaoke – a background tube is played while the user plays to the tune by one or more of: moving to a target instrument in space; moving between target instruments in space (a set of instruments is optionally placed by the therapist (or user or computer in space)); by just moving in the right direction; and/or by using multiple limb for more than one (VIRTUAL) instrument.

In an exemplary embodiment of the invention, games and/or music are used for rehabilitation of children. However, simpler music may need to be used for younger children. Additionally, music and common childhood games may be played with the assistance of rehabilitation system 100. Optionally, children group games are provided. Optionally, children
5 are outfitted with sensors so that their motions can be tracked and responsive music generated.

In an exemplary embodiment of the invention, music feedback and/or guidance is used to rehabilitate mentally damaged children, for example, children with Down's syndrome or children with Cerebral Palsy. Children with Cerebral Palsy often suffer from neglect of the paretic limb. In an exemplary embodiment of the invention, children with Cerebral Palsy are
10 rehabilitated by providing a musical game that requires them to use the paretic limb to participate in the game.

Similarly, music feedback and/or guidance is optionally used to rehabilitate the aged as various body parts begin to lose function due to ailments, illness, physical trauma and general old age.

15 **Portability**

In some embodiments of the invention, rehabilitation system 100 is constructed from elements which are lightweight and/or compact in order to allow portability of the device. Optionally, the elements of rehabilitation system 100 are easily assembled and calibrated so that a user is not restricted to a specific location. In some embodiments of the invention,
20 rehabilitation system 100 is supplied as a kit with all necessary parts, for example folding tables and/or poles to position cameras, in order to limit dependency of rehabilitation system 100 on external elements of a specific location. Optionally, the system 100 is adapted to be used outdoors. Optionally, the system is used at home.

Feedback

25 In an exemplary embodiment of the invention, the user receives immediate feedback, for example a distortion in the music being played or created responsive to the motion being performed. Optionally, delayed feedback is provided as well.

In some embodiments of the invention, rehabilitation system 100 supplies a user with a report regarding the user's performance relative to the requirements even for a single session.
30 Optionally, rehabilitation system 100 supplies long term performance reports regarding a user's progression over a period of many sessions. In some embodiments of the invention, rehabilitation system 100 supplies reports regarding a user's performance relative to other users and/or an average user. In an exemplary embodiment of the invention, progress report are

provided as musical files. In this way, a cognitively impaired and/or layman patient can be easily shown his progress.

In some embodiments of the invention, feedback reports can be accessed remotely by a user's therapist in order to monitor a user's progress, for example. Optionally, rehabilitation system 100 may send reports to a common database or directly to a therapist, for example by Email.

General

The use of music for rehabilitation and exercise is not limited by the particular examples shown above. In particular, music can be used, for example for the fine motor control rehabilitation methods described in US provisional application 60/566,079, the disclosure of which is incorporated herein by reference. For fine motor control, music can be used to provide feedback for a task which the user is not supposed to be looking at, such as writing or eating and in which music is used to indicate if a motion is correctly executed.

Music can be used for neural rehabilitation. For example, US provisional application 60/604,615, the disclosure of which is incorporated herein by reference uses neuronal sensing to determine when an action should be triggered. EEG signals can be used to modify music so a patient can recognize his neural activity.

Music can be used with EMG. For example, US provisional application 60/566,078, the disclosure of which is incorporated herein by reference musical signals can be used in addition to EMG or to prompt the patient that EMG is about to be or is being delivered. This may increase sensitivity.

Music can be used with gait training, for example such as described in US provisional application 60/633,428, the disclosure of which is incorporated herein by reference. In one example, music is used to set the pace of walking or to synchronize the multiple body motions. In another example, music is used to help a patient tell which one of the body motions (e.g., hips, legs, feet, shoulders) and on which body side (e.g., using stereo) is out of synch.

Music can be used for balance training, for example such as described in US provisional application 60/633,442, the disclosure of which is incorporated herein by reference. In one example, music is used to indicate balance between body sides. A channel which is too loud may be used to indicate a body portion applying too much force. Silence may be used to indicate balance, while a wobble will generate a cyclical tune and as balance is lost an alarm may increase in amplitude.

It should be appreciated that the above described methods of rehabilitation may be

varied in many ways, including, omitting or adding steps, changing the order of steps and the types of devices used. In addition, a multiplicity of various features, both of method and of devices have been described. In some embodiments of the invention, mainly methods are described; however, also apparatus adapted for performing the methods are considered to be

5 within the scope of the invention. It should be appreciated that different features may be combined in different ways. In particular, not all the features shown above in a particular embodiment are necessary in every embodiment of the invention. Further, combinations of the above features are also considered to be within the scope of some embodiments of the invention. Also within the scope of the invention are kits which include sets of a device, one or

10 more attachments and/or software. Also, within the scope is hardware, software and computer readable-media including such software which is used for carrying out and/or guiding the steps described herein, such as control of arm position and providing feedback. Section headings are provided for assistance in navigation and should not be considered as necessarily limiting the contents of the section. When used in the following claims, the terms "comprises", "includes",

15 "have" and their conjugates mean "including but not limited to". It should also be noted that the device is suitable for both males and female, with male pronouns being used for convenience.

It will be appreciated by a person skilled in the art that the present invention is not limited by what has thus far been described. Rather, the scope of the present invention is limited only by the following claims.

CLAIMS

1. Rehabilitation apparatus, comprising:
at least one motion support element adapted to support a motion of a part of a human;
5 a generator of rhythmic audio; and
a controller configured to correlate an audio output of said generator and said supported
motion.
2. Apparatus according to claim 1, wherein said motion support element is adapted for
10 attachment to a human.
3. Apparatus according to claim 1, wherein said motion support element is adapted for
gripping by a human.
- 15 4. Apparatus according to any of claims 1-3, wherein said motion support element is
adapted to assist a movement by a human.
5. Apparatus according to claim 4, wherein said assisting comprises moving a portion of
said human.
20
6. Apparatus according to claim 4 or claim 5, wherein said assisting comprises following a
motion of said human while providing at least part of a motive force.
7. Apparatus according to any of claims 4-6, wherein said assisting comprises restricting a
25 motion of said human.
8. Apparatus according to any of claims 1-7, wherein said motion support element is
adapted to resist a movement by a human.
- 30 9. Apparatus according to claim 8, wherein said resistance is not spatially uniform.
10. Apparatus according to any of claims 1-9, wherein said motion support element initiates
said motion.

11. Apparatus according to claim 10, wherein said motion support element moves said human.
- 5 12. Apparatus according to claim 10 or claim 11, wherein said motion support cues said human to start said motion.
13. Apparatus according to any of claims 1-12, wherein said controller generates said audio responsive to a correctness of said motion.
- 10 14. Apparatus according to claim 13, wherein said controller modifies said audio during a motion according to a correctness of said motion.
- 15 15. Apparatus according to claim 13 or claim 14, wherein said correctness is judged against a stored plan.
16. Apparatus according to any of claims 13-15, wherein said correctness is judged against one or more criteria.
- 20 17. Apparatus according to any of claims 13-16, wherein said controller distorts said audio according to a degree of error of said motion.
18. Apparatus according to any of claims 1-17, wherein said controller generates said audio to be timed to a desired movement by said human.
- 25 19. Apparatus according to claim 18, wherein said audio is generated before said movement.
20. Apparatus according to claim 18, wherein said audio is generated in time with said movement.
- 30 21. Apparatus according to claim 18, wherein said audio is generated during said movement including an anticipation of changes in said movement according to a plan stored in said

controller.

22. Apparatus according to any of claims 18-21, wherein said controller is configured to generate a score according to a synchronization between movements to specific spatial
5 locations and said audio.

23. Apparatus according to any of claims 18-22, wherein said controller is configured to mix a predetermined musical stream and audio generated according to said motion.

10 24. Apparatus according to any of claims 18-23, wherein said controller comprises a memory that links musical elements with motion elements.

25. Apparatus according to claim 24, wherein said controller generates said audio from musical elements corresponding to different body parts.

15

26. Apparatus according to claim 24, wherein said controller generates said audio from musical elements corresponding to different motions.

20 27. Apparatus according to any of claims 1-26, wherein said controller generates said audio according to a difference between a desired motion and an actual motion.

28. Apparatus according to any of claims 1-27, comprising a sensor which generates an indication of said motion.

25 29. Apparatus according to claim 28, wherein said controller generates a music stream according to said motion.

30. Apparatus according to claim 29, wherein said controller generates said stream as a set of instructions prior to detecting motion of said human.

30

31. Apparatus according to claim 30, wherein said controller generates series of musical notes and corresponding spatial motions.

32. Apparatus according to any of claims 1-31, wherein said controller has stored therein a plurality of trajectories of motion of said human.
33. Apparatus according to any of claims 1-31, wherein said controller has stored therein a
5 rehabilitation program for said human.
34. Apparatus according to any of claims 1-33, wherein said audio comprises music.
35. Apparatus according to any of claims 1-34, wherein said audio generator is adapted to
10 modify existing music.
36. Apparatus according to any of claims 1-35, wherein said controller is adapted to detect a physiological indicator of said human and generate music responsive thereto.
- 15 37. Rehabilitation apparatus comprising:
an audio generator;
at least one sensor adapted to sense a movement of a human;
a controller having stored therein rehabilitation information of a human,
wherein said controller is adapted to correlate said audio and said movement responsive
20 to said rehabilitation information.
38. Apparatus according to claim 37, wherein said apparatus is portable by an unassisted human.
- 25 39. Apparatus according to claim 37, wherein said apparatus is wearable.
40. Apparatus according to claim 37, wherein said apparatus comprises a stable base and at least one moving extension.
- 30 41. A method of rehabilitation, comprising:
coupling a patient to a rehabilitation system;
performing a rehabilitation activity by said patient; and
automatically generating music correlated with said rehabilitation activity.

42. A method according to claim 41, wherein automatically generating comprises providing at least one cue to said patient.
- 5 43. A method according to claim 41, wherein automatically generating comprises providing at least one musical instruction to said patient.
44. A method according to claim 41, wherein automatically generating comprises providing feedback on a physical action using music.
- 10 45. A method according to claim 41, wherein automatically generating comprises providing said music to other rehabilitated patients.
46. A method according to claim 41, comprising selecting music for a cognitively impaired
15 patient.
47. A method according to any of claims 41-46, wherein automatically generating comprises generating music according to a correctness of motion.
- 20 48. A method according to any of claims 41-47, wherein automatically generating comprises generating music timed according to a desired motion.
49. A method according to claim 48, wherein automatically generating comprises requiring said patient to reach spatial locations according to a musical feature of said music.
- 25 50. A method according to claim 48, wherein automatically generating comprises generating a musical channel to overlay an existing musical channel according to a motion of said patient.
- 30 51. A method according to any of claims 41-50, wherein automatically generating music comprises generating music to synchronize motions of different points in a body of said patient.
52. A method according to any of claims 41-50, wherein automatically generating music

WO 2005/086574
comprises said patient bringing music to said system.

PCT/IL2005/000137

1/4

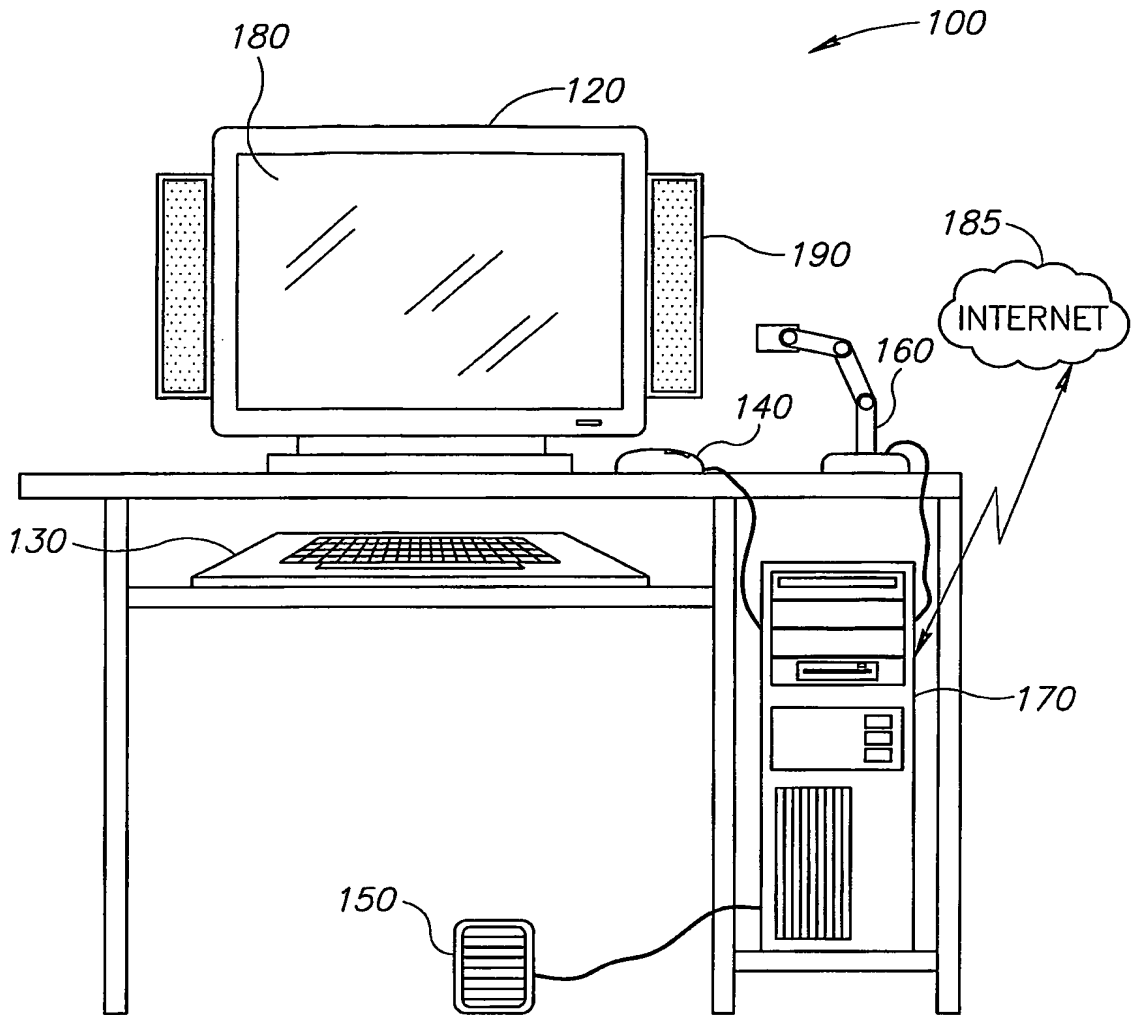

FIG. 1A

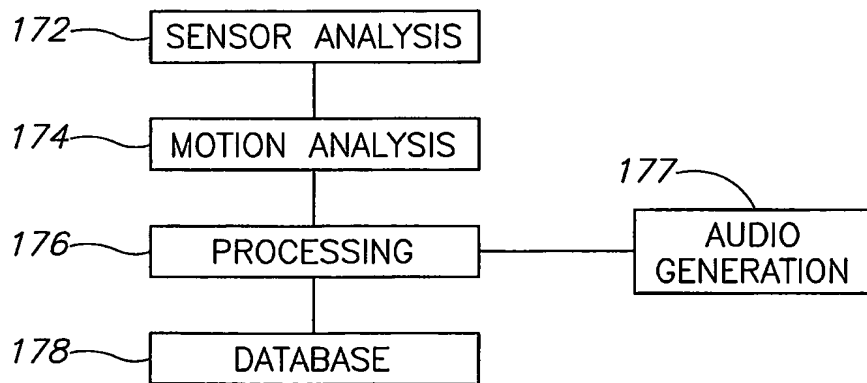

FIG. 1B

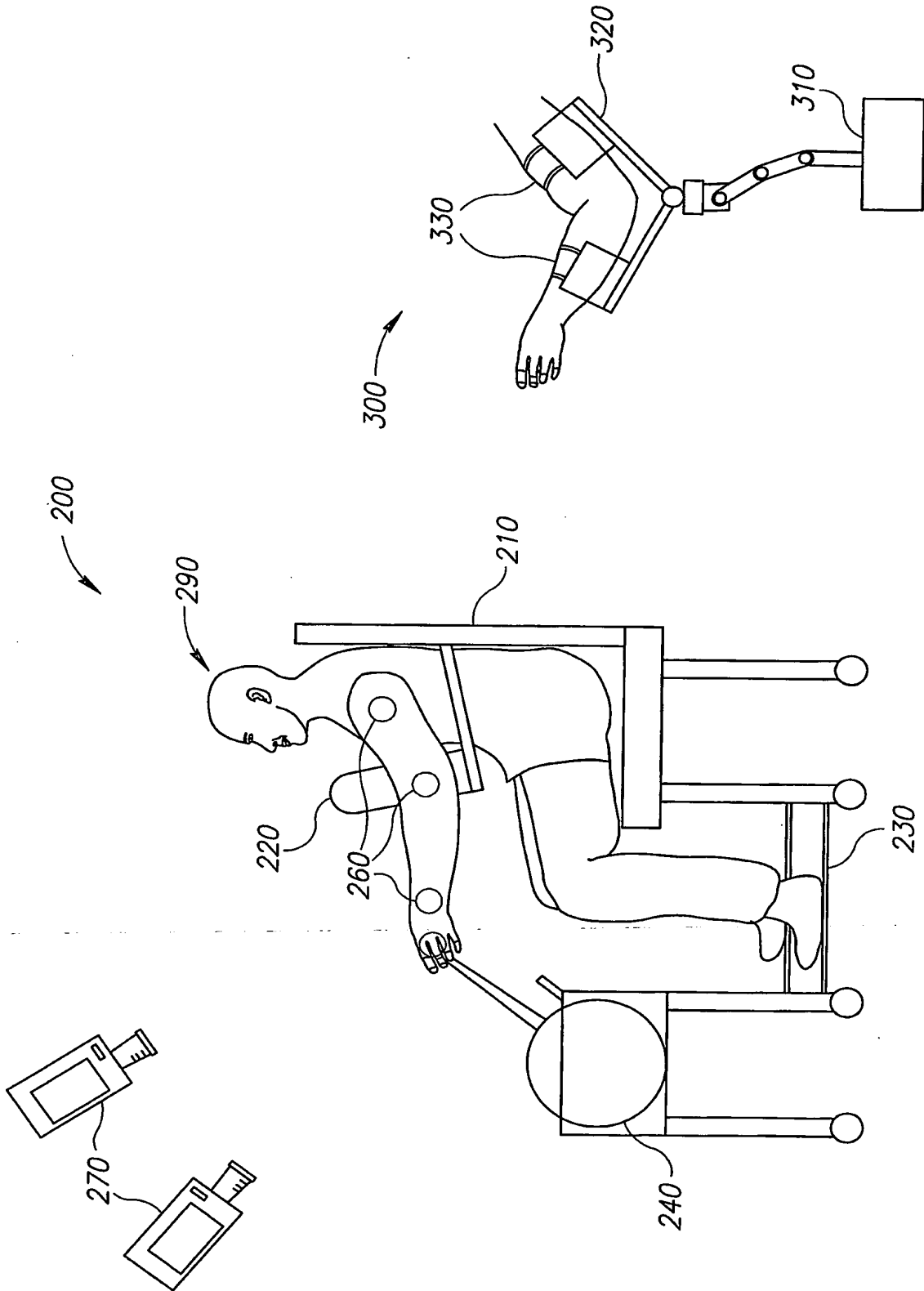

FIG.3

FIG.2

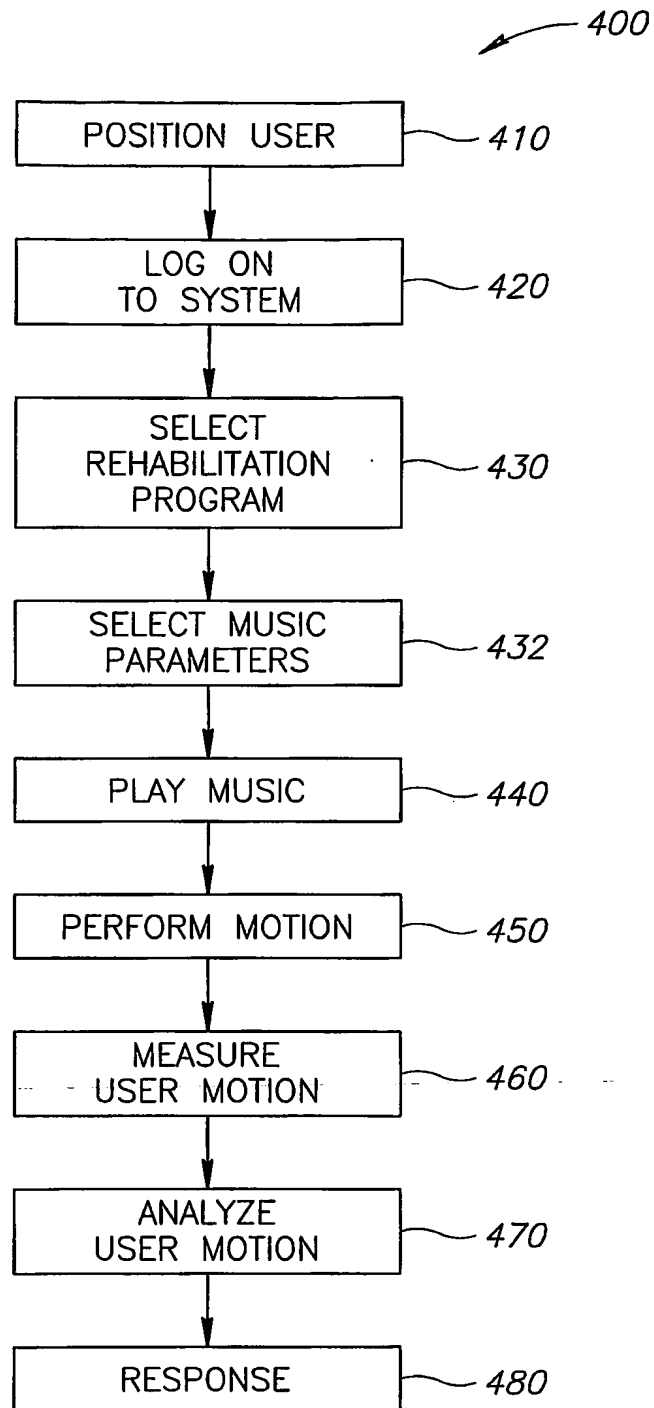

FIG.4

500

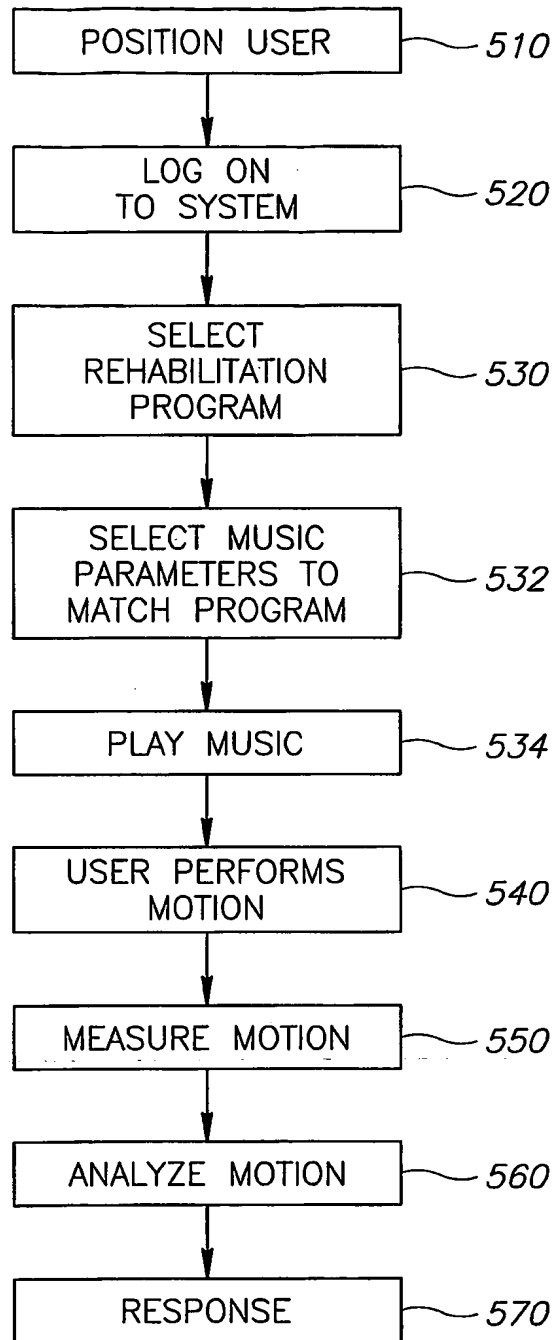

FIG.5

(19) World Intellectual Property
Organization
International Bureau



(43) International Publication Date
22 September 2005 (22.09.2005)

PCT

(10) International Publication Number
WO 2005/086574 A3

- (51) International Patent Classification⁷: A61H 1/02,
3/00, A63B 23/035
- (21) International Application Number:
PCT/IL2005/000137
- (22) International Filing Date: 4 February 2005 (04.02.2005)
- (25) Filing Language: English
- (26) Publication Language: English
- (30) Priority Data:
60/542,022 5 February 2004 (05.02.2004) US
60/633,429 7 December 2004 (07.12.2004) US
- (71) Applicant (for all designated States except US): REABIL-
ITY INC.; NERINE CHAMBERS, P.O. Box 905, Road
Town, Tortola (VG).
- (72) Inventors; and
- (75) Inventors/Applicants (for US only): EINAV, Omer

[IL/IL]; 42875 KFAR MONASH (IL). EINAV, Haim
[IL/IL]; 28 Shlush Street, 65149 Tel-Aviv (IL).

- (74) Agents: FENSTER, Paul et al.; FENSTER & COM-
PANY, INTELLECTUAL PROPERTY LTD., P.O. Box
10256, 49002 Petach Tikva (IL).
- (81) Designated States (unless otherwise indicated, for every
kind of national protection available): AE, AG, AL, AM,
AT, AU, AZ, BA, BB, BG, BR, BW, BY, BZ, CA, CH, CN,
CO, CR, CU, CZ, DE, DK, DM, DZ, EC, EE, EG, ES, FI,
GB, GD, GE, GH, GM, HR, HU, ID, IL, IN, IS, JP, KE,
KG, KP, KR, KZ, LC, LK, LR, LS, LT, LU, LV, MA, MD,
MG, MK, MN, MW, MX, MZ, NA, NI, NO, NZ, OM, PG,
PH, PL, PT, RO, RU, SC, SD, SE, SG, SK, SL, SM, SY, TJ,
TM, TN, TR, TT, TZ, UA, UG, US, UZ, VC, VN, YU, ZA,
ZM, ZW.
- (84) Designated States (unless otherwise indicated, for every
kind of regional protection available): ARIPO (BW, GH,
GM, KE, LS, MW, MZ, NA, SD, SL, SZ, TZ, UG, ZM,

[Continued on next page]

(54) Title: REHABILITATION WITH MUSIC

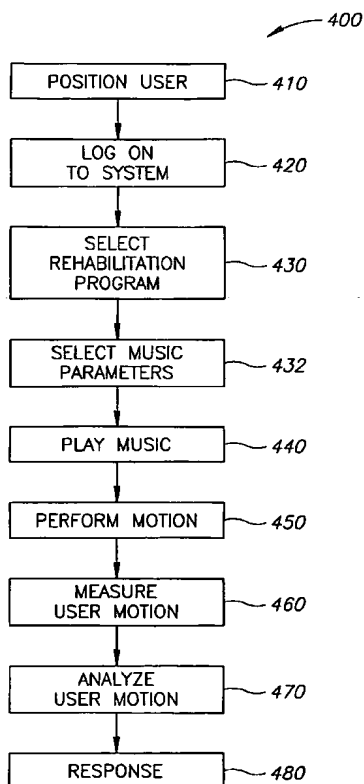

(57) Abstract: Rehabilitation apparatus, comprising: at least one motion support element adapted to support a motion of a part of a human; a generator of rhythmic audio; and a controller configured to correlate an audio output of said generator and said supported motion.

WO 2005/086574 A3



ZW), Eurasian (AM, AZ, BY, KG, KZ, MD, RU, TJ, TM), European (AT, BE, BG, CH, CY, CZ, DE, DK, EE, ES, FI, FR, GB, GR, HU, IE, IS, IT, LT, LU, MC, NL, PL, PT, RO, SE, SI, SK, TR), OAPI (BF, BJ, CF, CG, CI, CM, GA, GN, GQ, GW, ML, MR, NE, SN, TD, TG).

(88) Date of publication of the international search report:
22 December 2005

For two-letter codes and other abbreviations, refer to the "Guidance Notes on Codes and Abbreviations" appearing at the beginning of each regular issue of the PCT Gazette.

Published:

- *with international search report*
- *before the expiration of the time limit for amending the claims and to be republished in the event of receipt of amendments*

INTERNATIONAL SEARCH REPORT

Internat	Application No
PCT/IL2005/000137	

A. CLASSIFICATION OF SUBJECT MATTER
 IPC 7 A61H1/02 A61H3/00 A63B23/035

According to International Patent Classification (IPC) or to both national classification and IPC

B. FIELDS SEARCHED

Minimum documentation searched (classification system followed by classification symbols)
 IPC 7 A61H A63B G09B G06F A61B

Documentation searched other than minimum documentation to the extent that such documents are included in the fields searched

Electronic data base consulted during the international search (name of data base and, where practical, search terms used)
 EPO-Internal, WPI Data, PAJ

C. DOCUMENTS CONSIDERED TO BE RELEVANT

Category *	Citation of document, with indication, where appropriate, of the relevant passages	Relevant to claim No.
X	PATENT ABSTRACTS OF JAPAN vol. 014, no. 306 (C-0735), 3 July 1990 (1990-07-03) -& JP 02 102652 A (NIPPON AVIONICS CO LTD), 16 April 1990 (1990-04-16) abstract; figure	1-4,7-9, 13-38,40
X	US 5 397 865 A (PARK ET AL) 14 March 1995 (1995-03-14) column 3, line 23 - column 5, line 4 column 9, lines 40-60 column 10, lines 44-56 column 12, lines 24-28; figures	1-40
X	US 5 846 086 A (BIZZI ET AL) 8 December 1998 (1998-12-08) column 14, line 47 - column 16, line 10; claims 43,58; figures 13A,13B	1-4,7-9, 13-40
-/--		

Further documents are listed in the continuation of box C. Patent family members are listed in annex.

* Special categories of cited documents :

<p>*A* document defining the general state of the art which is not considered to be of particular relevance</p> <p>*E* earlier document but published on or after the international filing date</p> <p>*L* document which may throw doubts on priority claim(s) or which is cited to establish the publication date of another citation or other special reason (as specified)</p> <p>*O* document referring to an oral disclosure, use, exhibition or other means</p> <p>*P* document published prior to the international filing date but later than the priority date claimed</p>	<p>*T* later document published after the international filing date or priority date and not in conflict with the application but cited to understand the principle or theory underlying the invention</p> <p>*X* document of particular relevance; the claimed invention cannot be considered novel or cannot be considered to involve an inventive step when the document is taken alone</p> <p>*Y* document of particular relevance; the claimed invention cannot be considered to involve an inventive step when the document is combined with one or more other such documents, such combination being obvious to a person skilled in the art.</p> <p>*Z* document member of the same patent family</p>
--------------------------------------------------------------------------------------------------------------------------------------------------------------------------------------------------------------------------------------------------------------------------------------------------------------------------------------------------------------------------------------------------------------------------------------------------------------------------------------------------------------------------------------------------------------------------------------	--------------------------------------------------------------------------------------------------------------------------------------------------------------------------------------------------------------------------------------------------------------------------------------------------------------------------------------------------------------------------------------------------------------------------------------------------------------------------------------------------------------------------------------------------------------------------------------------------------------------------------------------------------------------------------------------------------------

Date of the actual completion of the international search 9 November 2005	Date of mailing of the international search report 17/11/2005
-----------------------------------------------------------------------------------------	-----------------------------------------------------------------------------

Name and mailing address of the ISA European Patent Office, P.B. 5818 Patentlaan 2 NL - 2280 HV Rijswijk Tel. (+31-70) 340-2040, Tx. 31 651 epo nl, Fax: (+31-70) 340-3016	Authorized officer Elmar Fischer
----------------------------------------------------------------------------------------------------------------------------------------------------------------------------------------	------------------------------------------------

INTERNATIONAL SEARCH REPORT

Internat	Application No
PCT/IL2005/000137	

C.(Continuation) DOCUMENTS CONSIDERED TO BE RELEVANT		
Category °	Citation of document, with indication, where appropriate, of the relevant passages	Relevant to claim No.
X	EP 0 304 538 A (JAPAN EM CO., LTD) 1 March 1989 (1989-03-01) column 13, lines 22-42 column 14, line 52 - column 15, line 13; figures 1,6A,7,24,30 -----	1-40
A	PATENT ABSTRACTS OF JAPAN vol. 2002, no. 09, 4 September 2002 (2002-09-04) -& JP 2002 127058 A (SANYO ELECTRIC CO LTD), 8 May 2002 (2002-05-08) abstract; figures -----	1-40

FURTHER INFORMATION CONTINUED FROM PCT/ISA/ 210

Continuation of Box II.1

Claims Nos.: 41-52

Claims 41-52 are directed to methods for treatment of the human or animal body by therapy - Article 17(2)(a)(i), Rule 39.1(iv) PCT.

In particular, independent method claim 41 includes medical treatment steps like coupling a patient to a rehabilitation system and performing a rehabilitation activity, the purpose and inevitable effect being therapeutic, namely rehabilitation of lost limb control.

INTERNATIONAL SEARCH REPORT

International application No.
PCT/IL2005/000137

Box II Observations where certain claims were found unsearchable (Continuation of item 2 of first sheet)

This International Search Report has not been established in respect of certain claims under Article 17(2)(a) for the following reasons:

1. Claims Nos.: 41-52
because they relate to subject matter not required to be searched by this Authority, namely:
see FURTHER INFORMATION sheet PCT/ISA/210
2. Claims Nos.:
because they relate to parts of the International Application that do not comply with the prescribed requirements to such an extent that no meaningful International Search can be carried out, specifically:
3. Claims Nos.:
because they are dependent claims and are not drafted in accordance with the second and third sentences of Rule 6.4(a).

Box III Observations where unity of invention is lacking (Continuation of item 3 of first sheet)

This International Searching Authority found multiple inventions in this international application, as follows:

1. As all required additional search fees were timely paid by the applicant, this International Search Report covers all searchable claims.
2. As all searchable claims could be searched without effort justifying an additional fee, this Authority did not invite payment of any additional fee.
3. As only some of the required additional search fees were timely paid by the applicant, this International Search Report covers only those claims for which fees were paid, specifically claims Nos.:
4. No required additional search fees were timely paid by the applicant. Consequently, this International Search Report is restricted to the invention first mentioned in the claims; it is covered by claims Nos.:

Remark on Protest

- The additional search fees were accompanied by the applicant's protest.
- No protest accompanied the payment of additional search fees.

INTERNATIONAL SEARCH REPORT

Information on patent family members

Intern

Application No

PCT/IL2005/000137

Patent document cited in search report	Publication date	Patent family member(s)	Publication date	
JP 02102652	A	16-04-1990	JP 1738464 C JP 4026858 B	26-02-1993 08-05-1992
US 5397865	A	14-03-1995	NONE	
US 5846086	A	08-12-1998	AT 175359 T AU 685953 B2 AU 2636595 A CA 2194159 A1 CN 1154661 A DE 69507145 D1 DE 69507145 T2 EP 0768909 A1 ES 2128062 T3 JP 10502465 T WO 9601138 A1 US 5554033 A	15-01-1999 29-01-1998 25-01-1996 18-01-1996 16-07-1997 18-02-1999 24-06-1999 23-04-1997 01-05-1999 03-03-1998 18-01-1996 10-09-1996
EP 0304538	A	01-03-1989	US 4907571 A	13-03-1990
JP 2002127058	A	08-05-2002	NONE	